

# ANTORCHAS TWECO



# PRODUCTOS EN EL MERCADO

Volumen







Medium Duty  
200 Amp

Heavy Duty  
400 Amp

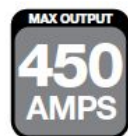
# SPRAYMASTER 450

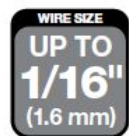

 <p>MIG/FLUX CORED</p>	 <p>MAX OUTPUT <b>450</b> AMPS</p>	 <p>DUTY CYCLE <b>80%</b></p>
 <p>WIRE SIZE <b>UP TO</b> <b>1/16"</b> (1.6 mm)</p>	 <p>COOLED <b>AIR</b></p>	 <p>USAGE <b>HEAVY</b> <b>DUTY</b></p>

**WELDING PROCESSES:**  
MIG (GMAW), Flux Cored (FCAW),  
Aluminum (GMAW)

- **Extended Trigger** length (with optional mechanical locking trigger) keeps hands farther away from the arc to reduce radiated heat
- **Compact, Ergonomic Handle Design** is balanced to pivot at the center of the handle for ease of use, thereby reducing operator fatigue
- **Wide Welding Applications** both Spray Transfer Mode & Pulse Welding
- **Increased Productivity** with the use of patented, extended life Eliminator front end consumables, helps the shop floor lower usage cost
- **Split Handle Case** provides access for ease of repairs in the field
- **Durable, Metal-Jacketed, Three-Layer Conductor Tube** rotates easily for different welding positions and lowers heat in the front end
- **Heavy Duty, Thick-Walled Contact Tip and Diffuser** increases tip life, decreases downtime with fewer tip changes and improves performance in high heat applications
- **Front and Rear Steel Spring Strain Relief** provides support to the Cablehoz® coming out of the rear of the handle and minimizes wire feed issues
- **Crimped Front Cablehoz Connection** for improved electrical conductivity
- **Field Repairable** mechanical Cablehoz connections
- **Interchangeable Front End Consumables** between Tweco® Classic No. and Tweco Spray Master series

# COMPATIBILIDAD:

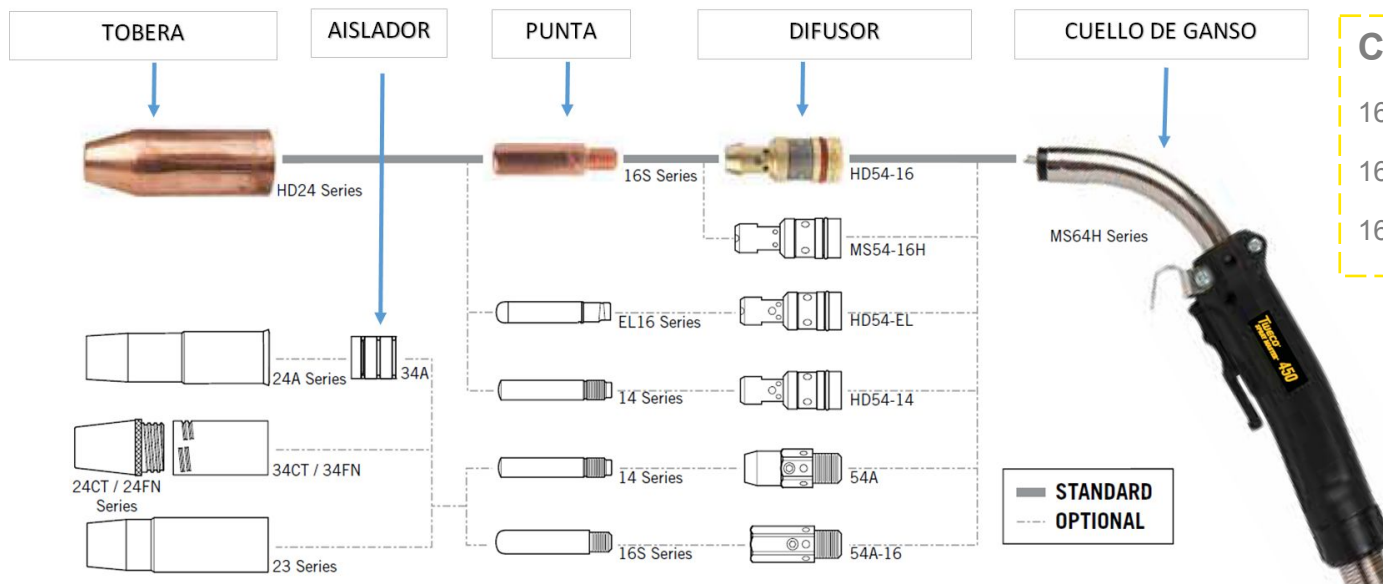

## CUELLOS:

- 1640-1319: 611266 TW COND. TUBE 60° MS64H-60
- 1640-1317: 613303 TW COND. TUBE 60° MS64H-60LM
- 1640-1105: 614255 TW COND. TUBE 45° 64J-45 -> (PFX)

## CONSUMIBLES:

- DIFUSOR
- PUNTA DE CONTACTO
- TOBERA 1C
- TOBERA 2C (TOBERA + AISLADOR)

## SERIE 14

- 54A
- Serie 14H
- 23-62 / 23H-62
- 24CT / 34CT

## SERIE 16 □ 2.5 Mayor duración

- HD54
- Serie 16
- 23H-62 / 24HD
- 24CT / 34CT

H / HD: HEAVY DUTY

SM450 w/S16

# COMPATIBILIDAD MEJORADA:

## CONSUMIBLES:

DIFUSOR

PUNTA DE CONTACTO

TOBERA 1C

TOBERA 2C (TOBERA + AISLADOR)

PROFAX

54A

Serie 14

23-62

24CT / 34CT

TWECO

54A

Serie 14 H

23H-62 / 24HD

24CT / 34CT

**H / HD: HEAVY DUTY**

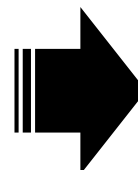

# SERIE 16:

- Las ANTORCHAS SPRAYMASTER 450 vienen implementadas con consumibles de la Serie 16.
- Las ANTORCHAS SPRAYMASTER 450, son compatibles con la Serie 14.

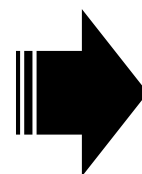



2.5 Mayor  
duración



H / HD: HEAVY  
DUTY

# VERSATILIDAD:

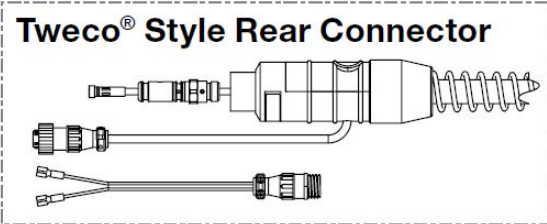
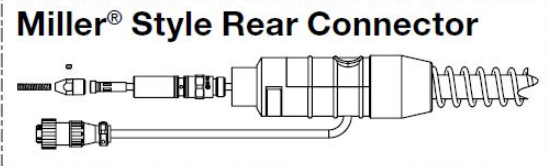
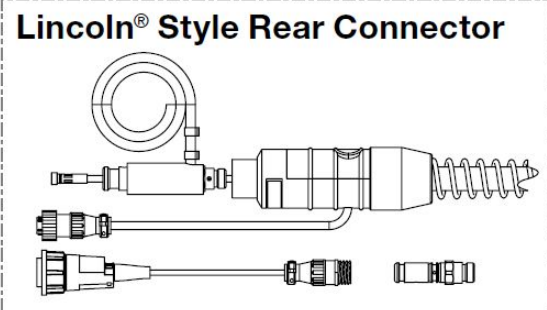
- Las ANTORCHAS SPRAYMASTER 450 se encuentra disponible en diferentes conexiones para atender las demanda de los diferentes equipos /fuentes del mercado.
- Disponible con cuello estándar y cuello largo (LM) de 2" más grande que permite una mejor performance en procesos Heavy Duty.

	PN	SAP	DETALLE
 <p><b>Tweco® Style Rear Connector</b></p>	1040-1052 1040-1053	615739 619613	TW SPRAYMASTER 450 15FT TW TW SPRAYMASTER 450 15FT-LM TW
 <p><b>Miller® Style Rear Connector</b></p>	1040-1062 1040-1063	615149 614141	TW SPRAYMASTER 450 15FT MIL TW SPRAYMASTER 450 15FT-LM MIL
 <p><b>Lincoln® Style Rear Connector</b></p>	1040-1072 1040-1073	617053 614808	TW SPRAYMASTER 450 15FT LIN TW SPRAYMASTER 450 15FT-LM LIN
 <p><b>Euro-Kwik Style Rear Connector</b></p>	1040-1077	612634	TW SPRAYMASTER 450 15FT EUR

# CUELLO LARGO:



# CONEXIONES:

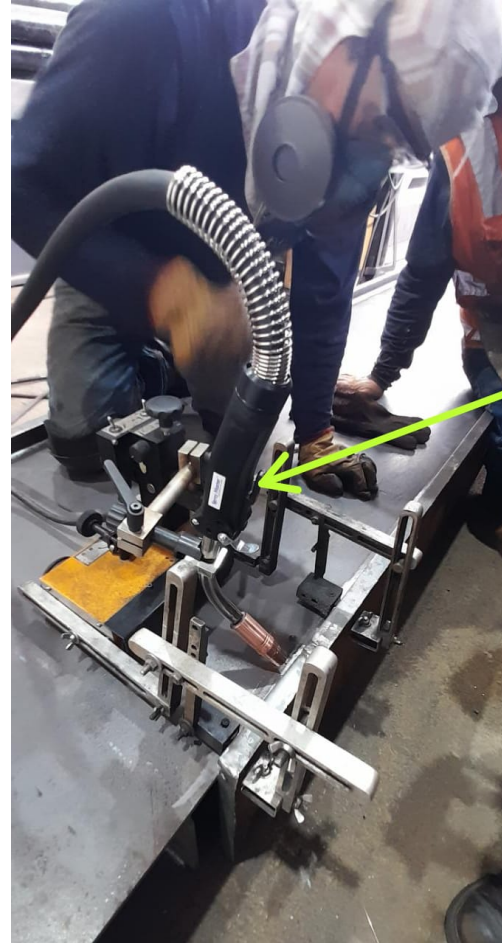



VICTOR® // THERMAL DYNAMICS® // TWECO® // ARCAIR® // EXATON™ // STOODY® // ALCOTEC® // AMI® // GCE®